

ORTAL

SPACE CREATOR FIREPLACES:

SPECIFICATIONS & PRODUCT GUIDE

ORTAL

ebnicca

1. NOTES

The appliance must be installed in accordance with the ORTAL AU/NZ Installation Manual.

The appliance must be properly connected to an approved chimney venting system. Refer to the specific appliance installation guide to determine vent size and pathway requirements. In addition, adhere to the following pre-installation guidelines:

- Use an approved DuraVent flue system as specified
- Consult the relevant authority to determine the need for a permit prior to starting the installation.
- It is the responsibility of the installer to ensure that this fireplace is installed in compliance with the manufacturer's instructions and all the applicable building codes. Contact your local distributor / dealer for correct flue and flue termination information.
- Always used a licensed gas fitter / plumber to install the appliance

IMPORTANT:

THIS IS NOT AN INSTALLATION MANUAL. PLEASE REFER TO THE DETAILED INSTALLATION MANUAL DELIVERED WITH THE APPLIANCE.

2. SPECIFICATIONS

MODEL	BURNER TYPE	INJECTORS	NOMINAL GAS CONSUMPTION	INLET PRESSURE	MANIFOLD PRESSURE	TURNDOWN PRESSURE	FLUE SIZE
75	B45	Marked 650: with 7x0.950mm orifice	26MJ/h	1.13kPA	0.82kPA	0.23kPA	107/164mm
120	B100	Marked 1200: with 7x1.275mm orifice	37MJ/h	0.69kPA	0.73kPA	0.26kPA	125/205mm
150	B135	Marked 1200: with 7x1.275mm orifice Marked 1400: with single 3.9mm orifice	55MJ/h	1.13kPA	0.61kPA	0.22kPA	125/205mm
200	B160	Marked 800: with 7x1.05mm orifice Marked 1400: with single 3.8mm orifice	52MJ/h	1.13kPA	0.50kPA	0.22kPA	125/205mm

3. DIMENSIONS

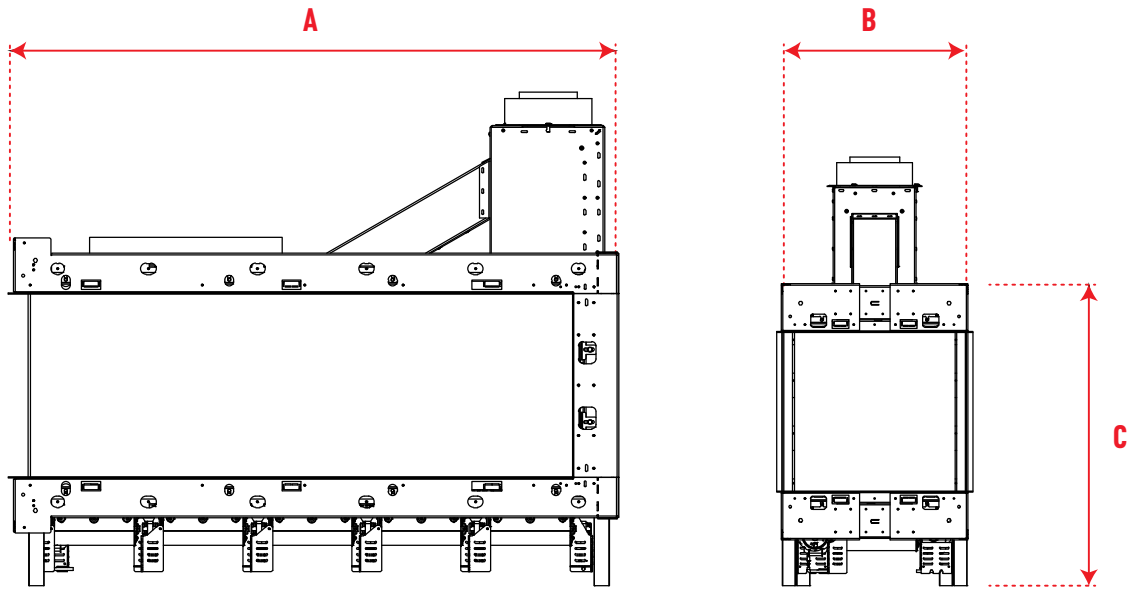

MODEL (all measurements in mm)	A WIDTH	B DEPTH	C HEIGHT	GLASS SIZE FRONT	GLASS SIZE SIDE
75	910	518	778	802 x 424	518 x 424
120	1402	518	797	1295 x 424	517 x 424
150	1703	518	797	1597 x 424	517 x 424
200	2213	518	797	2035 x 424	517 x 424

Note: Minimum height off of the floor for all front facing Ortal fireplaces is 210mm.
Appliance legs must not be removed.

4. FRAMING & CLADDING

OPTION 1: METAL STUDS FRAMING

The frame must be designed to carry the entire weight of the finished wall with no component being supported by the fireplace.

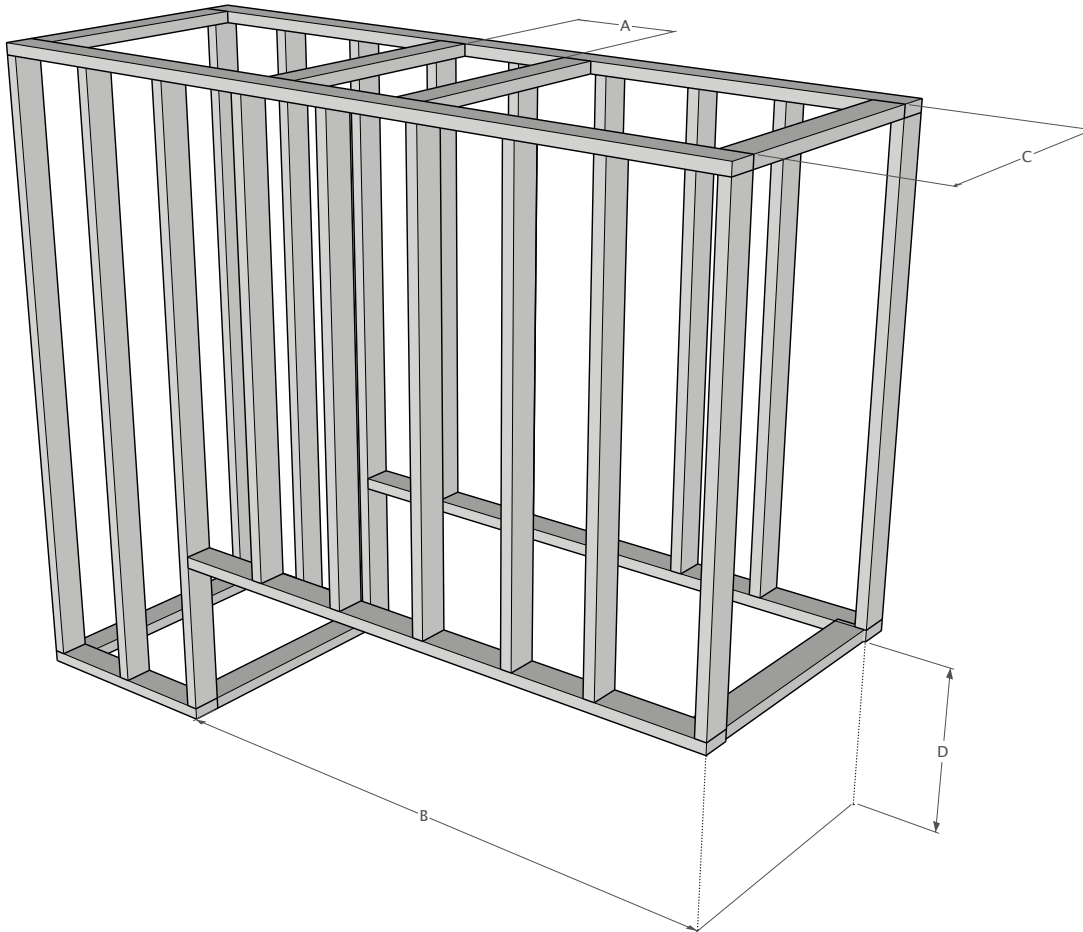

MODEL (all measurements in mm)	A	B	C	D
SC 75	222	964	492	800
SC 120	254	1456	492	819
SC 150	254	1757	492	819
SC 200	254	2267	492	819

CLADDING FOR METAL STUDS

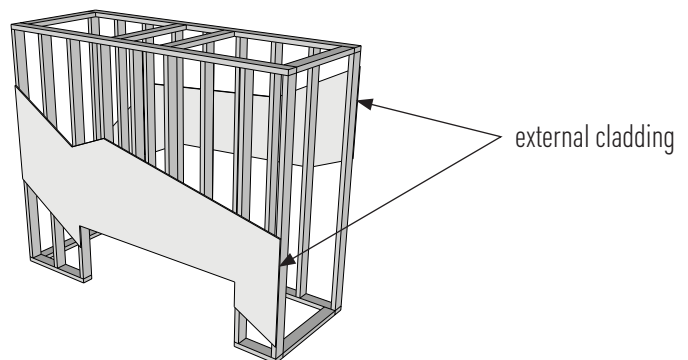

The framing structure must be clad **externally** with non combustible material and gaps sealed with a non-combustible fire proof sealant. We recommend the fireplace to be in position and flued prior to cladding.

4. FRAMING & CLADDING

OPTION 2: TIMBER STUDS WITH METAL SECTION

The frame must be designed to carry the entire weight of the finished wall with no component being supported by the fireplace.

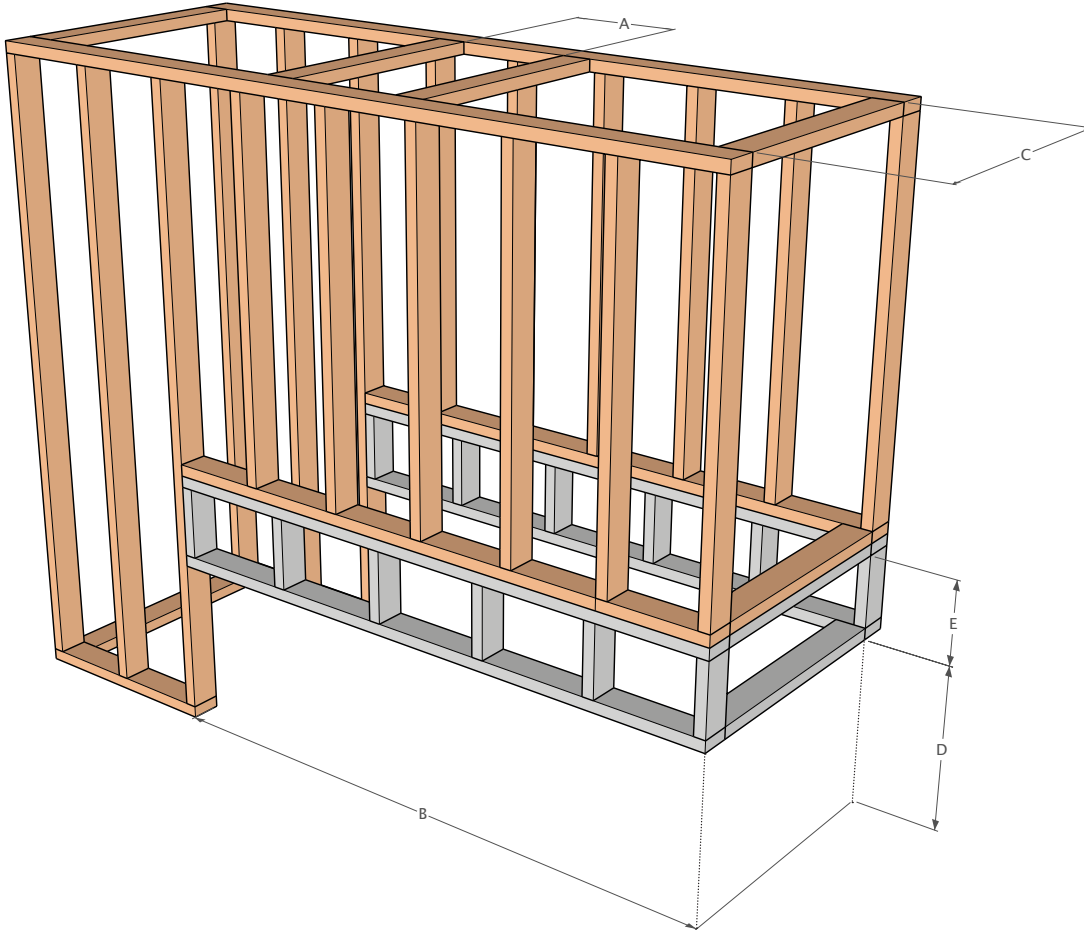

MODEL (all measurements in mm)	A	B	C	D	E
SC 75	222	964	492	800	483
SC 120	254	1456	492	819	464
SC 150	254	1757	492	819	464
SC 200	254	2267	492	819	464

CLADDING FOR TIMBER STUDS WITH METAL SECTION

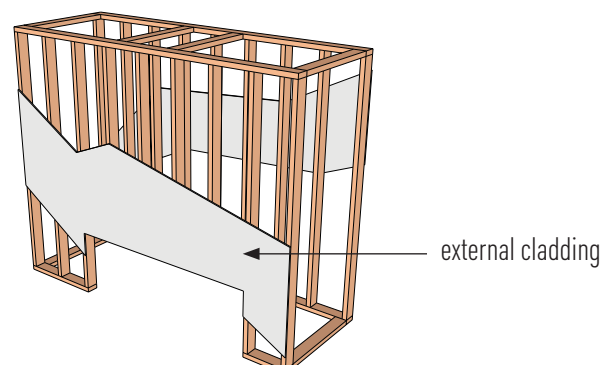

The framing structure must be clad **externally** with non combustible material and gaps sealed with a non-combustible fire proof sealant. We recommend the fireplace to be in position and flued prior to framing/cladding.

We recommend using 16mm Gypsum fire rated plasterboard or its equivalent for the enclosure of the fireplace chase.

5. VENTING

VENTING (convection air intake)

For mesh units:

- No need to create a convection air intake as the appliance is designed to supply fresh air through the viewing panel.

For double glass units:

- Convection air intake vents are required at the bottom of the cavity and can be placed at the front, side or back of the cavity.

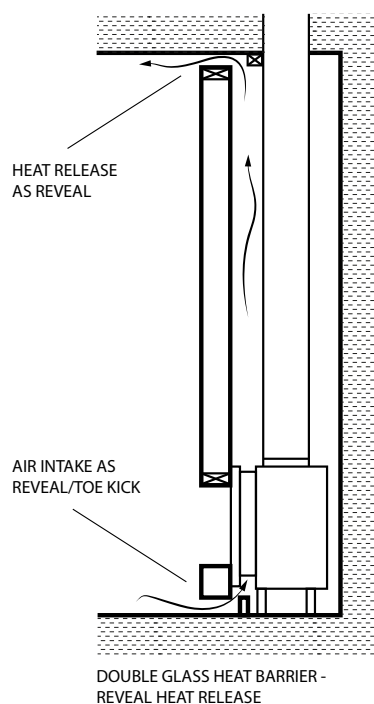
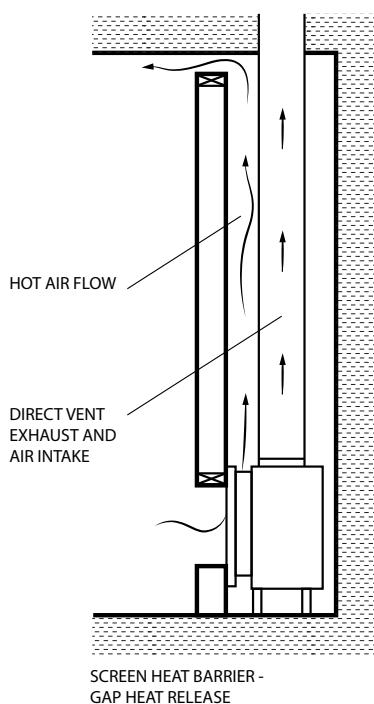

VENTING (Convection air outlet)

A convection air outlet is required for all Ortal fireplaces. This allows for heat building up within the fireplace cavity to be released back into the space, helping to keep the cavity walls cool. It must be located at the top of the fireplace cavity and be placed at a maximum of 150mm below the cavity ceiling. The vent can be located on the front, sides or back of the fireplace cavity, as long as it releases into an interior space and not outdoors.

MODEL	Heat release vent (min surface)
60 to 130	0.08m ²
150 to 200	0.13m ²
250	0.16m ²

These are minimum requirements and the surface can be greater if desired.

6. ACCESS PANEL

Access panels are recommended for all ORTAL fireplaces. They allow efficient and comfortable access to the fireplace receiver and valves, which is required for servicing purpose.

Access panels can be designed and positioned to minimise their visual impact as long as access to the valves and receiver is maintained. The size of the access panel may vary, but in all cases must allow the fireplace technician to effectively conduct a service. We recommend a minimum size of 200x200mm.

However, access panels are not the only option for servicing the fireplace operation mechanisms. A technician may also service the fireplace controls by going through the firebox. This procedure requires removing the glass panel(s), taking out the interior media and lifting the grill, burner and bottom side (explosion valve) of the unit. The technician would then return all these fireplace components when service is complete. The servicing procedure will take longer than through an access panel.

Fireplace installers are advised to consult with their clients, project architects or interior designers regarding the advantages and disadvantages of each service option.

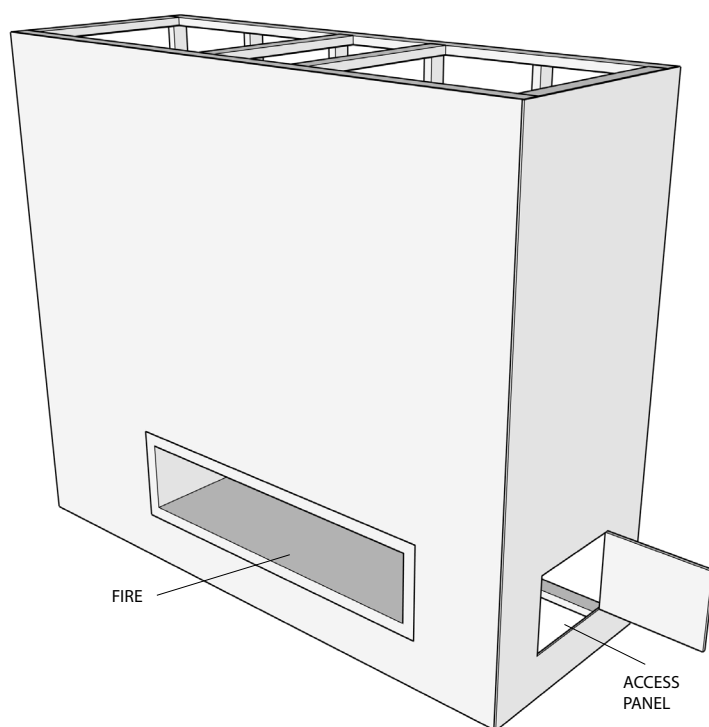

7. TV CLEARANCES

RECESSED INSTALLATION

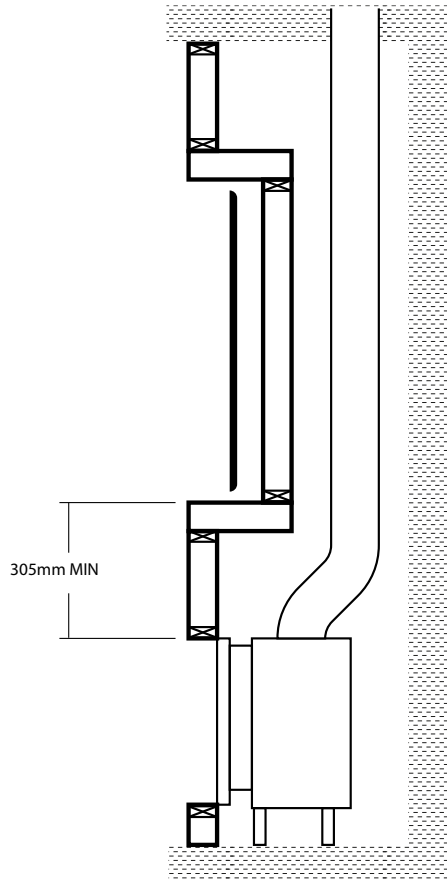

FLUSH INSTALLATION

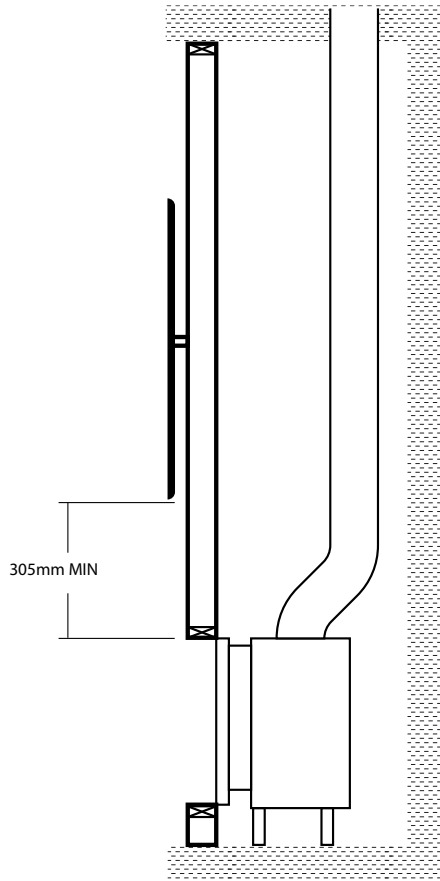

8. TESTING

THE ORTAL DECORATIVE ROOM SEALED GAS APPLIANCES HAVE BEEN TESTED AND APPROVED BY AGA & IAPMO-R&T FOR USE WITH NATURAL GAS (NG).

Australian Standard AS5263-0:2016 - Decorative Gas Log and Other Fuel Effect Appliances

Patent Pending for screen barrier glass bracket: USSN 60/040,074