

ORTAL

TUNNEL FIREPLACES:

SPECIFICATIONS & PRODUCT GUIDE

ORTAL

ebnicca

1. NOTES

The appliance must be installed in accordance with the ORTAL AU/NZ Installation Manual.

The appliance must be properly connected to an approved chimney venting system. Refer to the specific appliance installation guide to determine vent size and pathway requirements. In addition, adhere to the following pre-installation guidelines:

- Use an approved DuraVent flue system as specified
- Consult the relevant authority to determine the need for a permit prior to starting the installation.
- It is the responsibility of the installer to ensure that this fireplace is installed in compliance with the manufacturer's instructions and all the applicable building codes. Contact your local distributor / dealer for correct flue and flue termination information.
- Always used a licensed gas fitter / plumber to install the appliance

IMPORTANT:

THIS IS NOT AN INSTALLATION MANUAL. PLEASE REFER TO THE DETAILED INSTALLATION MANUAL DELIVERED WITH THE APPLIANCE.

2. SPECIFICATIONS

MODEL	BURNER TYPE	INJECTORS	NOMINAL GAS CONSUMPTION	INLET PRESSURE	MANIFOLD PRESSURE	TURNDOWN PRESSURE	FLUE SIZE
75 x 65	B45	Marked 650: with 7x0.950mm orifice	26MJ/h	1.13kPA	0.82kPA	0.23kPA	107/164mm
60 x 80	B45	Marked 650: with 7x0.950mm orifice	26MJ/h	1.13kPA	0.82kPA	0.23kPA	107/164mm
110 / 110H	B100	Marked 1200: with 7x1.275mm orifice	37MJ/h	0.69kPA	0.73kPA	0.26kPA	125/205mm
130 / 130H	B100	Marked 1200: with 7x1.275mm orifice	37MJ/h	0.69kPA	0.73kPA	0.26kPA	125/205mm
150 / 150H	B135	Marked 1200: with 7x1.275mm orifice Marked 1400: with single 3.9mm orifice	55MJ/h	1.13kPA	0.61kPA	0.22kPA	125/205mm
170 / 170H	B135	Marked 1200: with 7x1.275mm orifice Marked 1400: with single 3.9mm orifice	55MJ/h	1.13kPA	0.61kPA	0.22kPA	125/205mm
200 / 200H	B160	Marked 800: with 7x1.05mm orifice Marked 1400: with single 3.8mm orifice	52MJ/h	1.13kPA	0.50kPA	0.22kPA	125/205mm
250 / 250H	B160	Marked 800: with 7x1.05mm orifice Marked 1400: with single 3.8mm orifice	52MJ/h	1.13kPA	0.50kPA	0.22kPA	125/205mm

3. DIMENSIONS

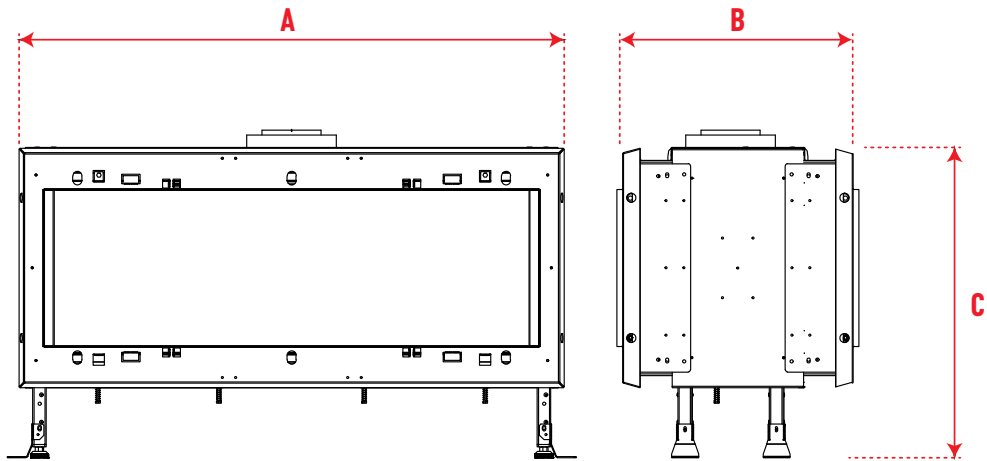

MODEL (all measurements in mm)	A WIDTH	B DEPTH	C HEIGHT	GLASS SIZE
75 x 65	872	510	966	778 x 650
60 x 80	644	510	1070	552 x 740
110	1216	510	692	1108 x 350
110 H	1216	510	892	1108 x 550
130	1368	510	692	1278 x 350
130 H	1368	510	892	1278 x 550
150	1636	510	692	1528 x 350
150 H	1636	510	892	1528 x 550
170	1837	510	692	1729 x 350
170 H	1837	510	892	1729 x 550
200	2076	510	692	1968 x 350
200 H	2076	510	892	1968 x 550
250	2550	510	745	2444 x 400
250 H	2550	510	745	2444 x 550

Note: Minimum height off of the floor for all front facing Ortal fireplaces is 210mm.
Appliance legs must not be removed.

4. FRAMING & CLADDING

OPTION 1: METAL STUDS FRAMING

The frame must be designed to carry the entire weight of the finished wall with no component being supported by the fireplace.

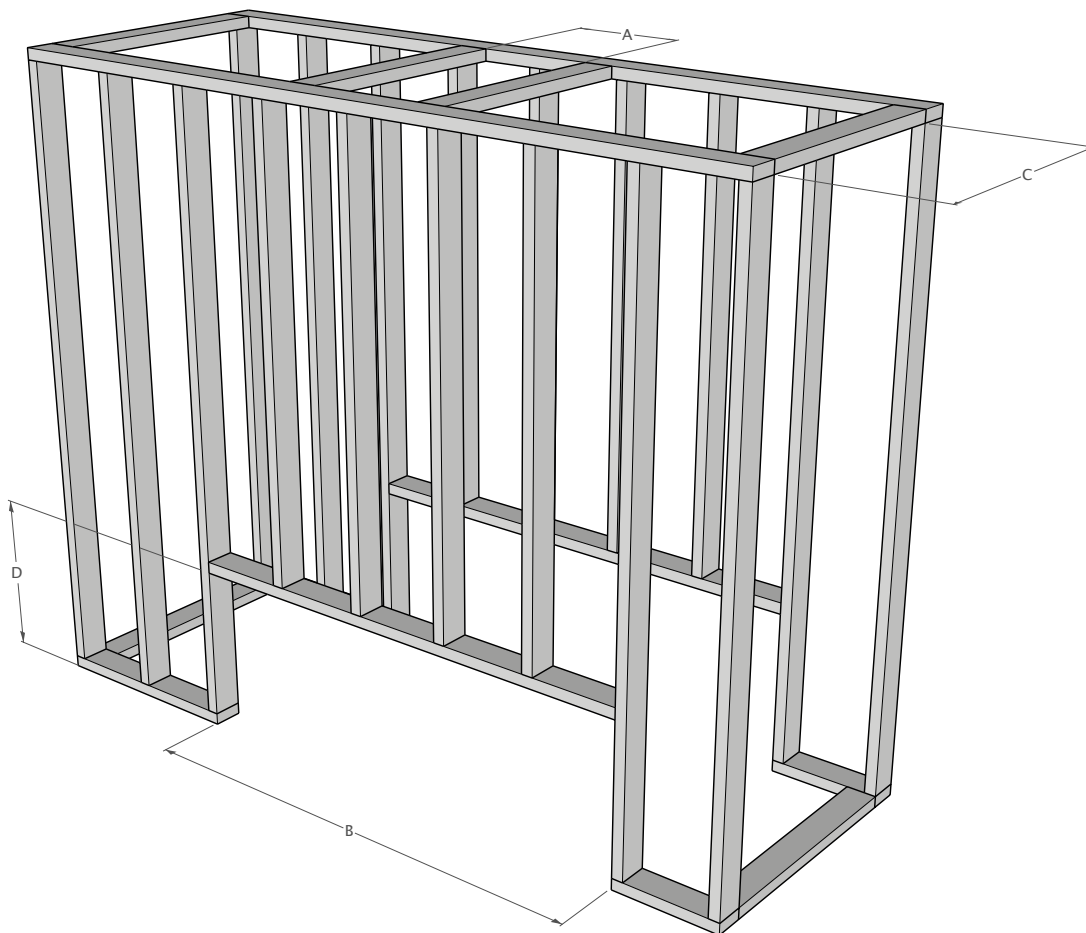

MODEL (all measurements in mm)	A	B	C	D
60 x 80 TN	222	778	484	1093
75 x 65 TN	222	1005	484	990
110 TN	254	1350	487	713
110H TN	254	1367	487	913
130 TN	254	1520	487	713
130H TN	254	1520	487	913
150 TN	254	1770	487	713
150H TN	254	1770	487	913
170 TN	254	1970	487	713
170H TN	254	1970	487	913
200 TN	254	2210	487	713
200H TN	254	2210	487	913
250 TN	254	2683	487	767
250H TN	254	2683	487	913

CLADDING FOR METAL STUDS

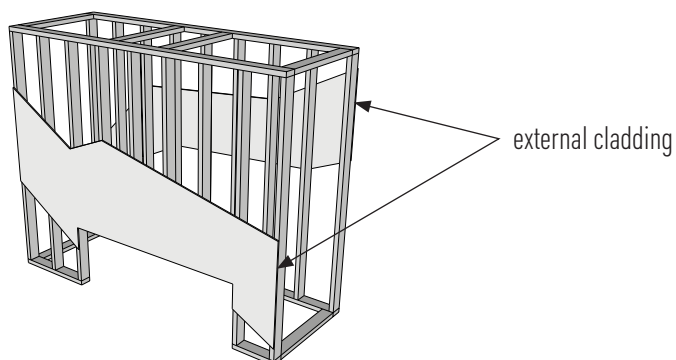

The framing structure must be clad **externally** with non combustible material and gaps sealed with a non-combustible fire proof sealant. We recommend the fireplace to be in position and flued prior to cladding.

4. FRAMING & CLADDING

OPTION 2: TIMBER STUDS WITH METAL SECTION

The frame must be designed to carry the entire weight of the finished wall with no component being supported by the fireplace.

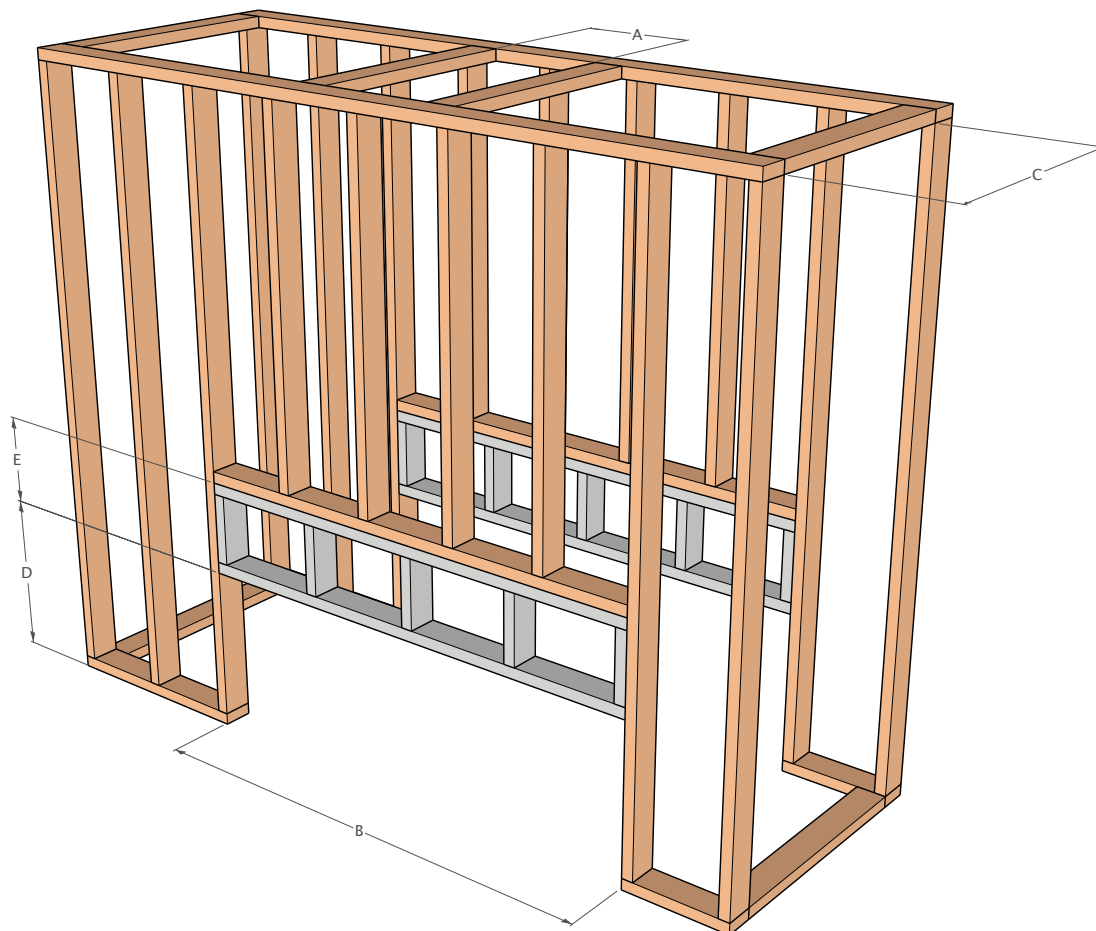

MODEL (all measurements in mm)	A	B	C	D	E
60 x 80 TN	222	778	484	1093	457
75 x 65 TN	222	1005	484	990	560
110 TN	254	1350	487	713	570
110H TN	254	1367	487	913	497
130 TN	254	1520	487	713	570
130H TN	254	1520	487	913	497
150 TN	254	1770	487	713	570
150H TN	254	1770	487	913	497
170 TN	254	1970	487	713	570
170H TN	254	1970	487	913	497
200 TN	254	2210	487	713	570
200H TN	254	2210	487	913	497
250 TN	254	2683	487	767	516
250H TN	254	2683	487	913	497

CLADDING FOR TIMBER STUDS WITH METAL SECTION

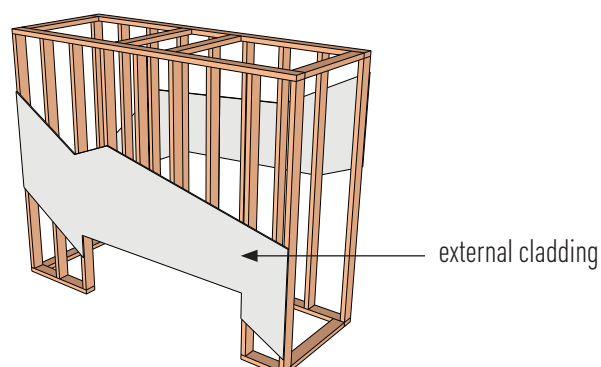

The framing structure must be clad **externally** with non combustible material and gaps sealed with a non-combustible fire proof sealant. We recommend the fireplace to be in position and flued prior to framing/cladding.

We recommend using 16mm Gypsum fire rated plasterboard or its equivalent for the enclosure of the fireplace chase.

5. VENTING

VENTING (convection air intake)

For mesh units:

- No need to create a convection air intake as the appliance is designed to supply fresh air through the viewing panel.

For double glass units:

- Convection air intake vents are required at the bottom of the cavity and can be placed at the front, side or back of the cavity.

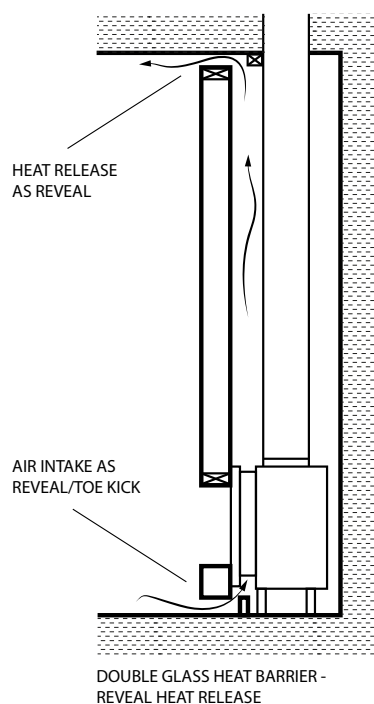
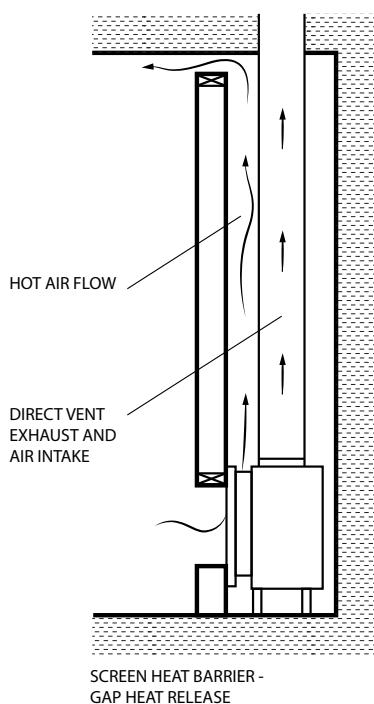

VENTING (Convection air outlet)

A convection air outlet is required for all Ortal fireplaces. This allows for heat building up within the fireplace cavity to be released back into the space, helping to keep the cavity walls cool. It must be located at the top of the fireplace cavity and be placed at a maximum of 150mm below the cavity ceiling. The vent can be located on the front, sides or back of the fireplace cavity, as long as it releases into an interior space and not outdoors.

MODEL	Heat release vent (min surface)
60 to 130	0.08m ²
150 to 200	0.13m ²
250	0.16m ²

These are minimum requirements and the surface can be greater if desired.

6. ACCESS PANEL

Access panels are recommended for all ORTAL fireplaces. They allow efficient and comfortable access to the fireplace receiver and valves, which is required for servicing purpose.

Access panels can be designed and positioned to minimise their visual impact as long as access to the valves and receiver is maintained. The size of the access panel may vary, but in all cases must allow the fireplace technician to effectively conduct a service. We recommend a minimum size of 200x200mm.

However, access panels are not the only option for servicing the fireplace operation mechanisms. A technician may also service the fireplace controls by going through the firebox. This procedure requires removing the glass panel(s), taking out the interior media and lifting the grill, burner and bottom side (explosion valve) of the unit. The technician would then return all these fireplace components when service is complete. The servicing procedure will take longer than through an access panel.

Fireplace installers are advised to consult with their clients, project architects or interior designers regarding the advantages and disadvantages of each service option.

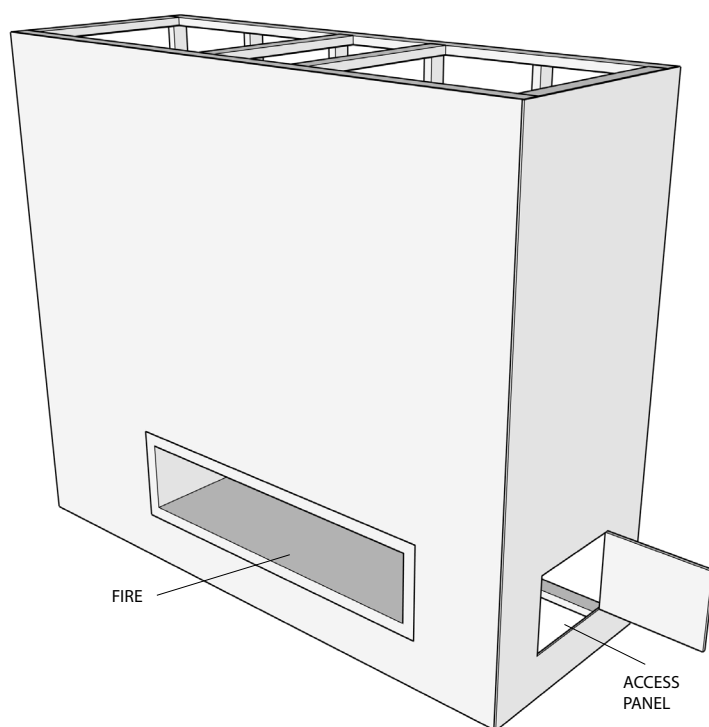

7. TV CLEARANCES

RECESSED INSTALLATION

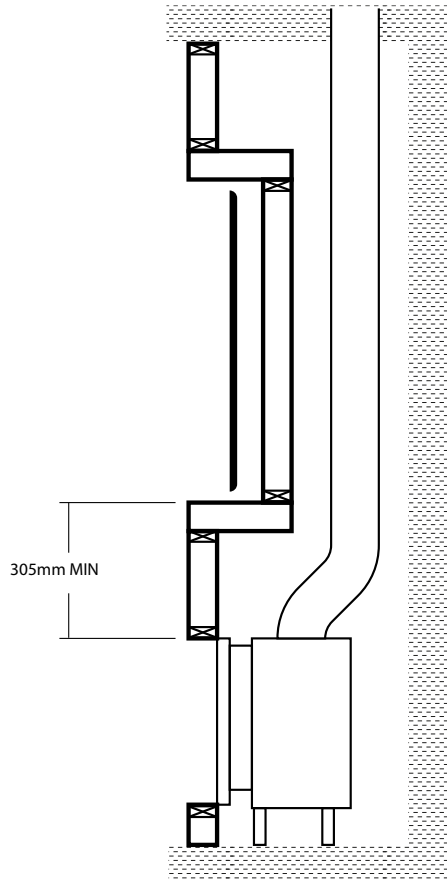

FLUSH INSTALLATION

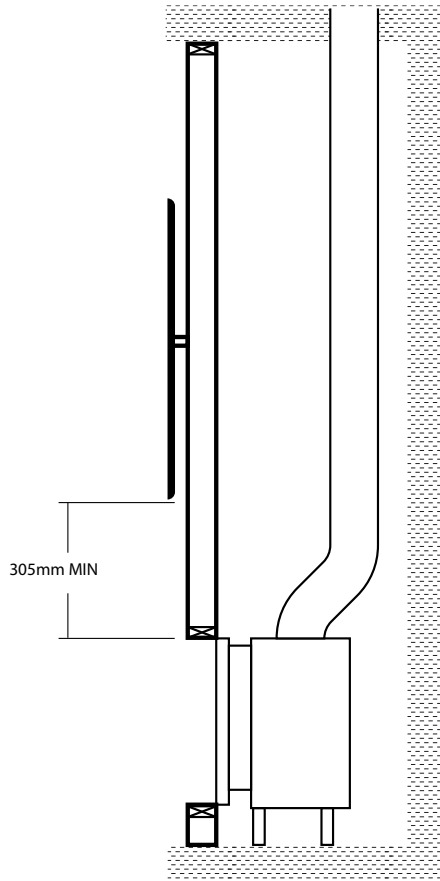

8. TESTING

THE ORTAL DECORATIVE ROOM SEALED GAS APPLIANCES HAVE BEEN TESTED AND APPROVED BY AGA & IAPMO-R&T FOR USE WITH NATURAL GAS (NG).

Australian Standard AS5263-0:2016 - Decorative Gas Log and Other Fuel Effect Appliances

Patent Pending for screen barrier glass bracket: USSN 60/040,074